

# APPLICATION NOTE

## *Interfacing the OBS-3 Turbidity Monitor with Campbell Scientific Dataloggers*



**CAMPBELL SCIENTIFIC, INC.**

815 W. 1800 N. • Logan, Utah 84321-1784 • (435) 753-2342 • FAX (435) 750-9540



## **DISCLAIMER**

This application note concerns interfacing another manufacturer's product with our data-loggers. We will attempt to provide accurate and up-to-date information in this note. However, changes to another manufacturer's product are beyond our control. Such changes may affect hookup, programming, and even safe use of the product. Also, this note should be used in conjunction with the original manufacturer's technical reference documentation. See their documentation for information concerning product use and safety. If you encounter out-of-date, incomplete, or incorrect information, please contact us so we can attempt to remedy the situation.

Because the product is manufactured by another company, their warranty applies. Contact the original manufacturer for warranty information, repairs, and recalibrations.

Our website (<http://www.campbellsci.com>) lists the updated notes.



**CAMPBELL SCIENTIFIC, INC.**

815 W. 1800 N. • Logan, Utah 84321-1784 • (435) 753-2342 • FAX (435) 750-9540



# Interfacing the OBS-3 Turbidity Monitor with Campbell Scientific Dataloggers

The OBS-3 Turbidity Monitor is a submersible probe manufactured and sold by D & A Instrument Company. This application note provides a diagram of connecting the OBS-3 to a CR10(X), 21X(L), CR23X, and CR500 datalogger and describes programming a datalogger to read this probe.

The standard output for the OBS-3 is 0 to 5 V, which may be used with the CR23X and 21X(L). If response over 1000 FTU is needed for use with the CR10(X) or CR500 datalogger, order the probe with the optional 0 to 2500 mV output range.

When turbidity is very high, the OBS-3 probe can generate an output greater than 5 V. To avoid the loss of data, ask D & A Instruments to install a voltage limiting circuit in the probe that clamps the output to 2.5 V.



The OBS-3 probe may draw over 30 mA. Because this power requirement is relatively high, we recommend you provide switched power, such as the switched 12 V on the CR10X and CR23X wiring panel. If power to the sensor is continuous, you must use AC power or a solar panel with excellent solar availability to maintain a good charge on the battery.

## Connections

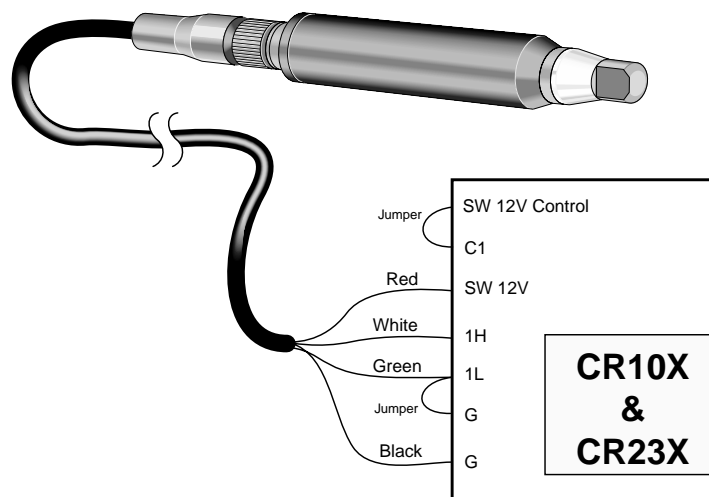

**FIGURE 1. Wiring Diagram of OBS-3 Using Datalogger's Switched 12 V**

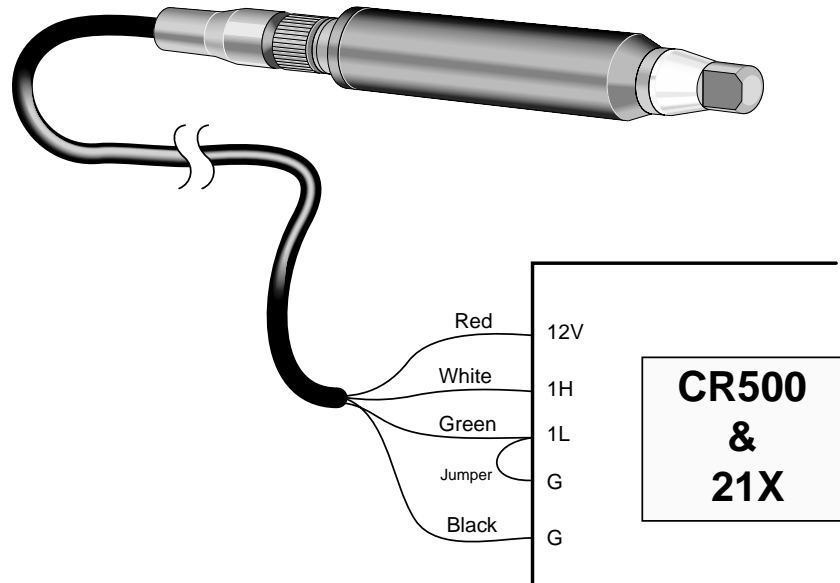

**FIGURE 2. Wiring Diagram of OBS-3 Without Using Switch 12 V**

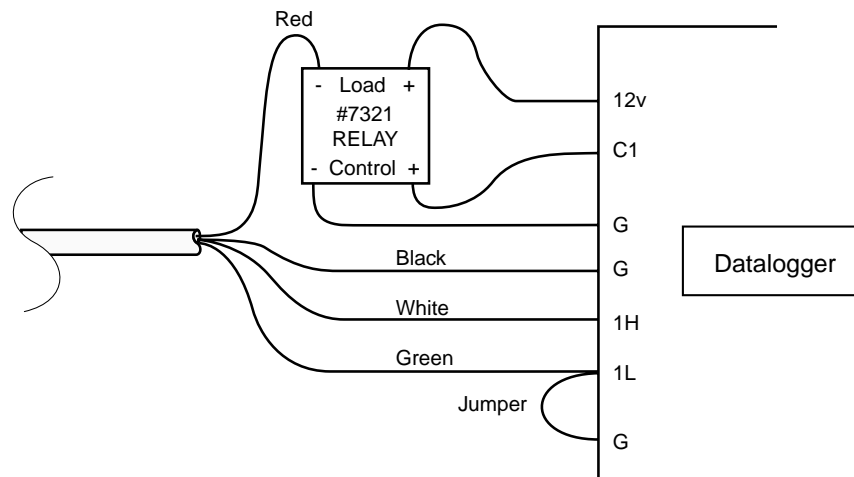

**FIGURE 3. Wiring Diagram for Connecting an OBS-3 to an External Relay and a Datalogger**

---

**Notes:**

1. The assignment of channel number (e.g., Diff Channel 1 or C1) may vary depending on the application.
  2. You may use a relay such as Campbell Scientific part #7321 instead of the switched 12 V connection on the CR10(X) and CR23X wiring panel. Since the CR500 and 21X wiring panels do not have switched 12 V, you will need an external relay if you need to conserve battery power.
- 

## Programming

Use Short Cut, Edlog, or the keyboard/display to program the datalogger to read the OBS-3 probe.

### Using Short Cut

Short Cut is the easiest and typically the preferred method for programming the datalogger. With Short Cut, you choose the OBS-3 probe and your output preferences from a series of menus, then Short Cut creates a custom program and wiring diagram for you.

### Using Edlog or the Keyboard/Display

Use Instruction 2--Differential Voltage to read the probe's millivolt signal. This instruction requires a multiplier to be calculated. The multiplier is the full scale FTU value divided by the probe's full scale millivolt output. Typically, the offset is zero.

### Edlog Program Example

The program on the following page reads an OBS-3 probe that's using switched 12 V power, either built-in or using an external relay. The program could be used for a CR10(X) or CR500. Except for parameters 2 and 5 in Instruction 2 (Differential Voltage), the 21X and CR23X programs are the same. The appropriate parameters for the 21X and CR23X are displayed in bold lettering.

;Program to read OBS-3 Turbidity Monitor with 0 to 2500 mV output  
;and 2000 FTU.

\*Table 1 Program

;Pick the execution interval you need. Five seconds is OK for testing.

01: 5.0 Execution Interval (seconds)

;Power-up probe and provide warm-up time

1: Do (P86)

1: 41 Set Port 1 High ; Port number corresponds to C1

2: Excitation with Delay (P22)

1: 1 Ex Channel

2: 0 Delay W/Ex (units = 0.01 sec)

3: 100 Delay After Ex (units = 0.01 sec)

4: 0 mV Excitation

;Read millivolt signal

3: Volts (DIFF) (P2)

1: 1 Reps

2: 25 2500 mV 60 Hz Rejection Range

**21X is 5: ± 5000 mV Slow**

**CR23X is 25: ± 5000 mV 60 Hz Rejection Range**

3: 1 DIFF Channel

4: 1 Loc [ Turbidity ]

5: 0.8 Mult ; (2000 FTU)/(2500 mV)

**CR23X and 21X would be 2000/5000 = 0.4**

6: 0.0 Offset

;Remove power from probe

4: Do (P86)

1: 51 Set Port 1 Low

;Measure system voltage

5: Batt Voltage (P10)

1: 2 Loc [ BATT\_VOLT ]

;Output every hour the date and the average turbidity, maximum  
;turbidity with the time of occurrence, and battery voltage.

6: If time is (P92)

1: 0 Minutes into a

2: 60 Interval

3: 10 Set Output Flag High

7: Real Time (P77)

1: 1110 Year, Day, Hour/Minute

8: Average (P71)

1: 1 Reps

2: 1 Loc [ Turbidity ]

9: Maximize (P73)

1: 1 Reps

2: 10 Value with Hr\_Min

3: 1 Loc [Turbidity ]

10: Sample (P70)

1: 1 Reps

2: 2 Loc [ BATT\_VOLT ]

## Maintenance and Troubleshooting

Follow the maintenance and troubleshooting procedures that are outlined in the OBS-3 technical manual provided by D & A Instrument Company.